

QX20P AC S4 1000X550

MAXIMUM PERFORMANCE AND VERSATILITY



QX20P

The QX equipped with platform is an highly versatile electrical pallet truck that, thanks to its folding platform, can be used in confined spaces or over medium distances with an excellent travel speed.

The sturdy frame, the AC traction motor technology and the energy recovery braking system are just a few examples of the high technology of this machine.

FORKS

Robust cast iron forks, highly resistant to torsion and impact.

AC
QX 20P



TILLER EVOLUTION

Fully integrated ergonomic technopolymer tiller system including finger tip throttle and proportional fork controls, safety pushbutton, horn, turtle button, hourmeter, battery status indicator as standard equipment.



MOTORS

Lifting and traction motors have both a voltage of 24 Volt. The vertical assembly not only allows a more rapid access to all the parts but also minimizes room cluttering-up and wiring stress.



TECHNOLOGY AND SAFETY

The powerful ZAPI ACEX controller is connected to 3 sensors that automatically adjust speed control and reduce it up to 6 km/h when at least one of the following events occurs:

1. Lateral protection guards are not raised and are not brought to the "run" position.
2. The turning radius sensor registers a curve with an angle over 8 degrees.
3. The footplate is kept in closed position.



WHEELS

Wheel drive of considerable power and big size. Two stabilizing wheels enable movement even on more difficult surfaces, thus guaranteeing maximum stability in any condition of use.

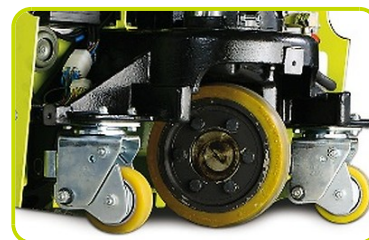

ROLLERS

Standard configuration provided with tandem polyurethane rollers. Available single rollers as optional.



Description

1.1 Manufacturer			PR INDUSTRIAL
Lift			ELECTRIC
1.3 Drive			ELECTRIC
1.4 Operator type			PEDESTRIAN/ STAND-ON PLATFORM
1.5 Load capacity	Q	Kg	2000
1.6 Load centre distance	c	mm	500
1.8 Load axle to end forks	x	mm	823
1.9 Wheel base	y	mm	1223

Weights

2.1 Service weight (battery included)		Kg	556
2.2 Axle load, laden rear		Kg	970
2.2 Axle load, laden front		Kg	1586
2.3 Axle load, unladen front		Kg	121
2.3 Axle load, unladen rear		Kg	435

Tyres/Chassis

3.1 Tyres: front wheels			POLY.C.
3.1 Tyres: stabilizers wheels - Front			POLY.C.
3.1 Tyres: rear wheels			POLY.C.
3.2 Tyre size: Steering wheels - Width		mm	75
3.2 Tyre size: Steering wheels - Diameter		mm	230
3.3 Tyre size: Load rollers - Diameter		mm	85
3.3 Tyre size: Load rollers - Width		mm	80
3.4 Tyre size: stabilizers wheels front - Diameter		mm	100
3.4 Tyre size: stabilizers wheels front - Width		mm	40
3.5 Tyre size: rear wheels - Q.ty (X=driven)		nr	1X
3.6 Tread, front	b10	mm	380
3.7 Tread, rear	b11	mm	506

Dimensions

4.4 Lift height	h3 mm	115
4.9 Height of tiller in drive position max	h14 mm	1450
4.9 Height of tiller in drive position min	h14 mm	1107
4.15 Height, lowered	h13 mm	85
4.19 Overall length with lowered platform	l1 mm	2026
4.19 Overall length with raised platform	l1 mm	1656
4.20 Length to face of forks with lowered platform	l2 mm	1026
4.20 Length to face of forks with raised platform	l2 mm	656
4.21 Overall width	b1 mm	716
4.22 Fork dimensions - Thickness	s mm	55
4.22 Fork dimensions - Width	e mm	170
4.22 Fork dimensions - Length	l mm	1000
4.25 Distance between fork arms	b5 mm	550
4.32 Ground clearance, centre of wheelbase	m2 mm	30
4.34 Aisle width with lowered platform	Ast mm	2615
4.34 Aisle width with raised platform	Ast mm	2257
4.35 Turning radius with lowered platform	Wa mm	1865
4.35 Turning radius with raised platform	Wa mm	1507

Performance data

5.1 Travel speed laden	Km/h	6.0
5.1 Travel speed unladen	Km/h	6.0
5.1 Travel Speed Laden with platform in lowered position	Km/h	8.0
5.1 Travel speed unladen with platform in lowered position	Km/h	8.0
5.2 Lifting speed laden	m/s	0.04
5.2 Lifting speed unladen	m/s	0.05
5.3 Lowering speed laden	m/s	0.05
5.3 Lowering speed unladen	m/s	0.04
5.8 Max gradeability laden	%	8
5.8 Max gradeability unladen	%	20
5.10 Service brake		Electric

Electric motors

6.1 Drive motor power	kW	2.0
6.2 Lift motor power	kW	1.2
Battery Type	Tipo	TRACTION
6.4 Battery voltage	V	24
6.4 Battery capacity, Min	Ah	180
6.4 Battery capacity, Max	Ah	230
6.5 Battery weight, Min	Kg	185
6.5 Battery weight, Max	Kg	218
8.4 Sound level at driver's ear	dB(A)	56.4

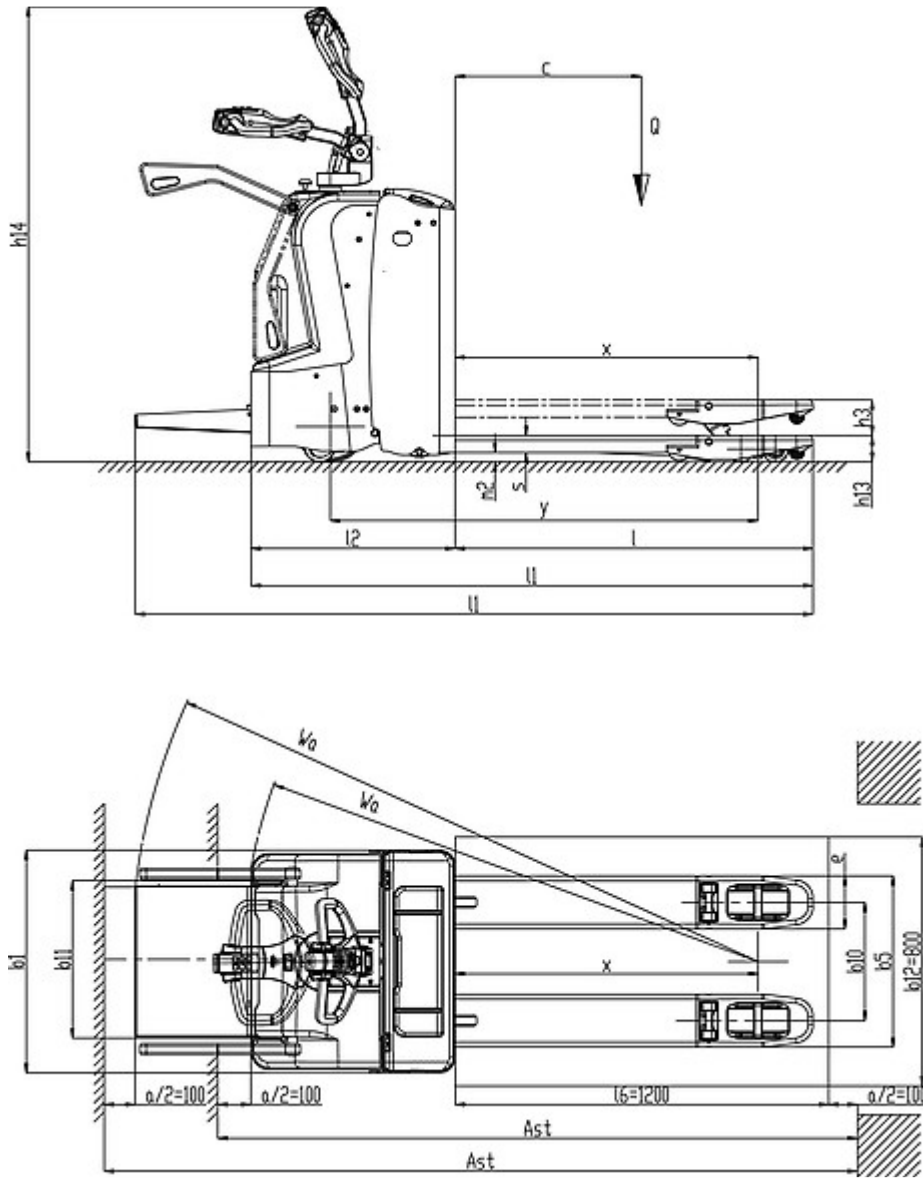

The information is aligned with the Data file at the time of download. Printed on 12/02/2019 (ID 493)

©2019 | PR INDUSTRIAL s.r.l. | All rights reserved | Image shown may not reflect actual package. Specifications subject to change without notice

