



7-Series Forklifts

Pneumatic Diesel and LPG 2.0 to 3.5 ton Series

D20/25/30/33S-7, D35C-7 Euro Phase IIIA/IIIB

G20/25/30/33P-7, G35C-7 (Non-Certi/Tier III)

G20N/G25N/G30N/G33N-7, G35NC-7 (Tier III)



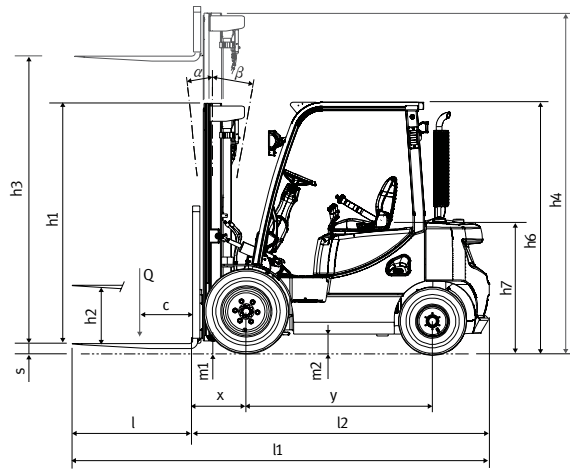
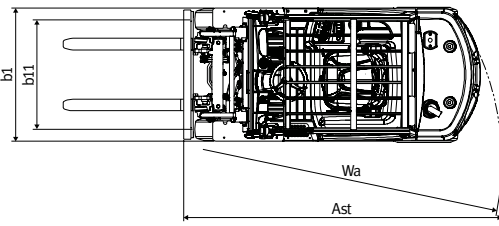

D33S-7/G33N-7/G33P-7

Mast type	Maximum Fork Height	Maximum Lowered Height	Fully Extended Height	Free Lift	Rated Load Capacities								
					D33S-7/G33N-7/G33P-7								
					Tilt Angle				Load Capacities				
					Single Pneu.		Double Pneu		Single Solid		Single Pneu.	Double Pneu	Single Solid
					FWD	BWD	FWD	BWD	FWD	BWD	LC 500mm	LC 500mm	LC 500mm
	mm	mm	mm	mm	deg	deg	deg	deg	deg	deg	kg	kg	kg
STD	2,030	1,565	3,290	152	6	10	6	10	6	10	3,250	3,250	3,250
	2,580	1,840	3,840	152	6	10	6	10	6	10	3,250	3,250	3,250
	2,950	2,025	4,210	152	6	10	6	10	6	10	3,250	3,250	3,250
	3,230	2,165	4,490	152	6	10	6	10	6	10	3,250	3,250	3,250
	3,500	2,415	4,765	152	6	10	6	10	6	10	3,250	3,250	3,250
	3,800	2,565	5,065	152	6	10	6	10	6	10	3,250	3,250	3,250
	3,950	2,640	5,215	152	6	10	6	10	6	10	3,175	3,250	3,250
	4,350	2,840	5,615	152	6	5	6	10	6	10	3,175	3,250	3,250
	4,960	3,140	6,215	152	6	3	6	10	6	8	2,450	3,125	3,200
	FF	2,580	1,840	3,840	640	6	10	6	10	6	10	3,250	3,250
2,950		2,025	4,210	825	6	10	6	10	6	10	3,250	3,250	3,250
3,230		2,165	4,490	965	6	10	6	10	6	10	3,250	3,250	3,250
3,600		2,415	4,865	1,215	6	10	6	10	6	10	3,250	3,250	3,250
FFT	3,900	1,890	5,165	690	6	8	6	8	6	8	3,250	3,250	3,250
	4,290	2,025	5,570	825	6	5	6	8	6	8	3,250	3,250	3,250
	4,730	2,165	5,990	965	6	3	6	8	6	8	2,900	3,175	3,250
	5,560	2,515	6,815	1,315	6	3	6	8	6	5	1,750	2,975	3,050
	6,010	2,665	7,265	1,465	6	3	6	5	6	3	1,350	2,875	2,950

D35C-7/G35NC-7/G35C-7

Mast type	Maximum Fork Height	Maximum Lowered Height	Fully Extended Height	Free Lift	Rated Load Capacities								
					D35S-7/G35NC-7/G35C-7								
					Tilt Angle				Load Capacities				
					Single Pneu.		Double Pneu		Single Solid		Single Pneu.	Double Pneu	Single Solid
					FWD	BWD	FWD	BWD	FWD	BWD	LC 500mm	LC 500mm	LC 500mm
	mm	mm	mm	mm	deg	deg	deg	deg	deg	deg	kg	kg	kg
STD	1,800	1,565	3,060	152	6	10	6	10	6	10	3,500	3,500	3,500
	2,350	1,840	3,610	152	6	10	6	10	6	10	3,500	3,500	3,500
	2,720	2,025	3,980	152	6	10	6	10	6	10	3,500	3,500	3,500
	3,000	2,165	4,260	152	6	10	6	10	6	10	3,500	3,500	3,500
	3,495	2,415	4,760	152	6	10	6	10	6	10	3,500	3,500	3,500
	3,655	2,565	4,915	152	6	10	6	10	6	10	3,500	3,500	3,500
	3,805	2,640	5,065	152	6	10	6	10	6	10	3,500	3,500	3,500
	4,205	2,840	5,465	152	6	8	6	10	6	10	3,425	3,425	3,500
	4,805	3,140	6,065	152	6	3	6	8	6	8	3,250	3,275	3,375
	FF	2,350	1,840	3,610	640	6	10	6	10	6	10	3,500	3,500
2,720		2,025	3,980	825	6	10	6	10	6	10	3,500	3,500	3,500
3,000		2,165	4,260	965	6	10	6	10	6	10	3,500	3,500	3,500
3,495		2,415	4,755	1,215	6	10	6	10	6	10	3,500	3,500	3,500
FFT	3,555	1,890	4,815	690	6	8	6	8	6	8	3,400	3,400	3,400
	3,960	2,025	5,220	825	6	8	6	8	6	8	3,400	3,400	3,400
	4,380	2,165	5,640	965	6	5	6	8	6	8	3,375	3,375	3,400
	4,820	2,335	6,085	1,135	6	3	6	8	6	8	3,250	3,250	3,350
	5,205	2,515	6,465	1,315	6	3	6	8	6	5	2,600	3,150	3,250
	5,655	2,665	6,915	1,465	6	3	6	5	6	3	1,975	3,050	3,150

Note: These load capacities are based on the standard chassis without side shifter.

AUTHORIZED DEALER



Doosan Industrial Vehicle Europe nv

Europark-Noord 36A
9100 Sint-Niklaas
Belgium

Tel.: +32 3 760 09 87
Fax: +32 3 760 09 89
Website: www.doosan-iv.eu

EUD25S7-181108ENV7 (November 2018)