



B40X-7 / B45X-7 / B50XC-7 / B50X-7

7-SERIES FORKLIFTS

Electric 4.0 to 5.0 ton capacity
4 wheel



Technical Data according to VDI 2198

Characteristics	1.1	Manufacturer			DOOSAN
	1.2	Manufacturer's type designation			B40X-7
	1.3	Drive : electric(battery or mains) ,diesel, petrol ,fuel gas, manual			Electric
	1.4	Operator type : hand, pedestrian, standing, seated, order-picker			Driver seated
	1.5	Load capacity/rated load	kg	Q	4,000
	1.6	Load centre distance	mm	c	500
	1.8	Load distance, centre of drive axle to fork	mm	x	572
	1.9	Wheelbase	mm	y	2,000
	Weight	2.1	Service weight (with min. weight of battery)	kg	
2.2		Axle loading, loaded front/rear	kg		9,874 / 1,138
2.3		Axle loading, unloaded front/rear	kg		3,730 / 3,282
Tyres	3.1	Tires: pneumatic (P), superelastic (SE), cushion (C)			SE
	3.2	Tire size, front			250 - 15
	3.3	Tire size, rear			7.00 - 12
	3.5	Wheels, number front/rear (x=driven wheels)			2x/2
	3.6	Tread width, front	mm	b11	1,168
	3.7	Tread width, rear	mm	b12	1,111
	Dimensions	4.1	Tilt of mast/fork carriage forward (α)/backward(β)	deg	α / β
4.2		Height, mast lowered	mm	h1	2,330
4.3		Free lift	mm	h2	160
4.4		Lift (with STD 2-stage mast)	mm	h3	3,250
		Lift height		h23	3,300
4.5		Height, mast extended	mm	h4	4,170
4.7		Height to top of overhead guard	mm	h6	2,340
4.8		Seat height/stand height	mm	h7	1,297
4.12		Towing coupling height	mm	h10	415
4.19		Overall length	mm	l1	4,007
4.20		Length to face of forks	mm	l2	2,957
4.21		Overall width	mm	b1	1,470
4.22		Fork dimensions	mm	s / e / l	50 / 150 / 1,200
4.23		Fork carriage ISO 2328. Class/type A, B			III A
4.24		Fork carriage width	mm	b3	1,250
4.24a		Fork Spacing (min/max)	mm		310 x 1182
4.31		Ground clearance, with load, below mast	mm	m1	120
4.32		Ground clearance, centre of wheelbase	mm	m2	160
4.33		Aisle width for pallets 1000 x 1200 crossways	mm	Ast	4,392
4.34		Aisle width for pallets 800 x 1200 lengthways	mm	Ast	4,592
4.35	Turning radius	mm	Wa	2,620	
4.36	Internal turning radius	mm	b13	877	
Performance	5.1	Travel speed, loaded / unloaded	km/h		15 / 16
	5.2	Lift speed, loaded / unloaded	mm/s		0.35 / 0.47
	5.3	Lowering speed, loaded / unloaded	mm/s		0.48 / 0.45
	5.6	Maximum drawbar pull, loaded / unloaded, 5 minute rating	N		18620 / 18620
	5.8	Maximum gradeability, loaded / unloaded, 5 minute rating	%		17 / 27
	5.10	Service brake			FOOT / HYD
Parking brake				HAND / MECH	
Electrical engine	6.1	Drive motor rating S2 60 minute	kW		10 X 2
	6.2	Lift motor rating at S3 15%	kW		28
	6.3	Battery acc. to DIN 43531 / 35/36 A, B, C, no			DIN43536A
	6.4	Battery voltage/nominal capacity K5	V/Ah		80 / 720
	6.5	Battery weight (min)	kg		2,160
		Battery dimensions L/W/H	mm		990 / 1,028 / 784
Others	8.1	Type of drive control unit			Inverter AC
	8.2	Operating pressure for attachments	bar	System	190
				Attachment	155
	8.4	Sound level at the driver's ear according to EN 12 053	dB (A)		

	DOOSAN	DOOSAN	DOOSAN
	B45X-7	B50XC-7	B50X-7
	Electric	Electric	Electric
	Driver seated	Driver Seated	Driver Seated
	4,500	4,990	5,000
	500	500	500
	572	572	572
	2,000	2,000	2,000
	7,427	7,734	7,763
	10,607 / 1,320	11,415 / 1,318	11,450 / 1,312
	3,695 / 3,732	3,735 / 3,998	3,770 / 3,992
	SE	SE	SE
	28 x 12.5 - 15	28 x 12.5 - 15	28 x 12.5 - 15
	7.00 - 12	7.00 - 12	7.00 - 12
	2x/2	2x/2	2x/2
	1,160	1,160	1,160
	1,111	1,111	1,111
	6 / 9	6 / 9	6 / 9
	2,340	2,340	2,340
	160	160	160
	3,250	3,250	3,250
	3,300	3,300	3,300
	4,180	4,180	4,205
	2,335	2,335	2,335
	1,303	1,303	1,303
	415	415	415
	4,007	4,037	4,037
	2,957	2,987	2,987
	1,470	1,470	1,470
	50 / 150 / 1,200	50 / 150 / 1,200	50 / 150 / 1,200
	III A	III A	IV A
	1,250	1,250	1,330
	310 x 1,182	310 x 1,182	340 x 1,290
	130	130	130
	160	160	160
	4,392	4,417	4,417
	4,592	4,617	4,617
	2,620	2,645	2,645
	879	879	879
	15 / 16	15 / 16	15 / 16
	0.35 / 0.47	0.31 / 0.47	0.31 / 0.47
	0.48 / 0.45	0.48 / 0.45	0.48 / 0.45
	18,620 / 18,620	18,620 / 18,620	18,620 / 18,620
	16 / 26	15 / 25	15 / 25
	FOOT / HYD	FOOT / HYD	FOOT / HYD
	HAND / MECH	HAND / MECH	HAND / MECH
	10 X 2	10 X 2	10 X 2
	28	28	28
	DIN43536A	DIN43536A	DIN43536A
	80 / 720	80 / 720	80 / 720
	2,160	2,160	2,160
	990 / 1,028 / 784	990 / 1,028 / 784	990 / 1,028 / 784
	Inverter AC	Inverter AC	Inverter AC
	210	230	230
	155	155	155
	70	70	70

Note: Specification values quoted in this specification sheet has been rounded. Performance may vary due to operation conditions. Products and specifications are subject to improvement and change without prior notices.

Dimensional Drawing

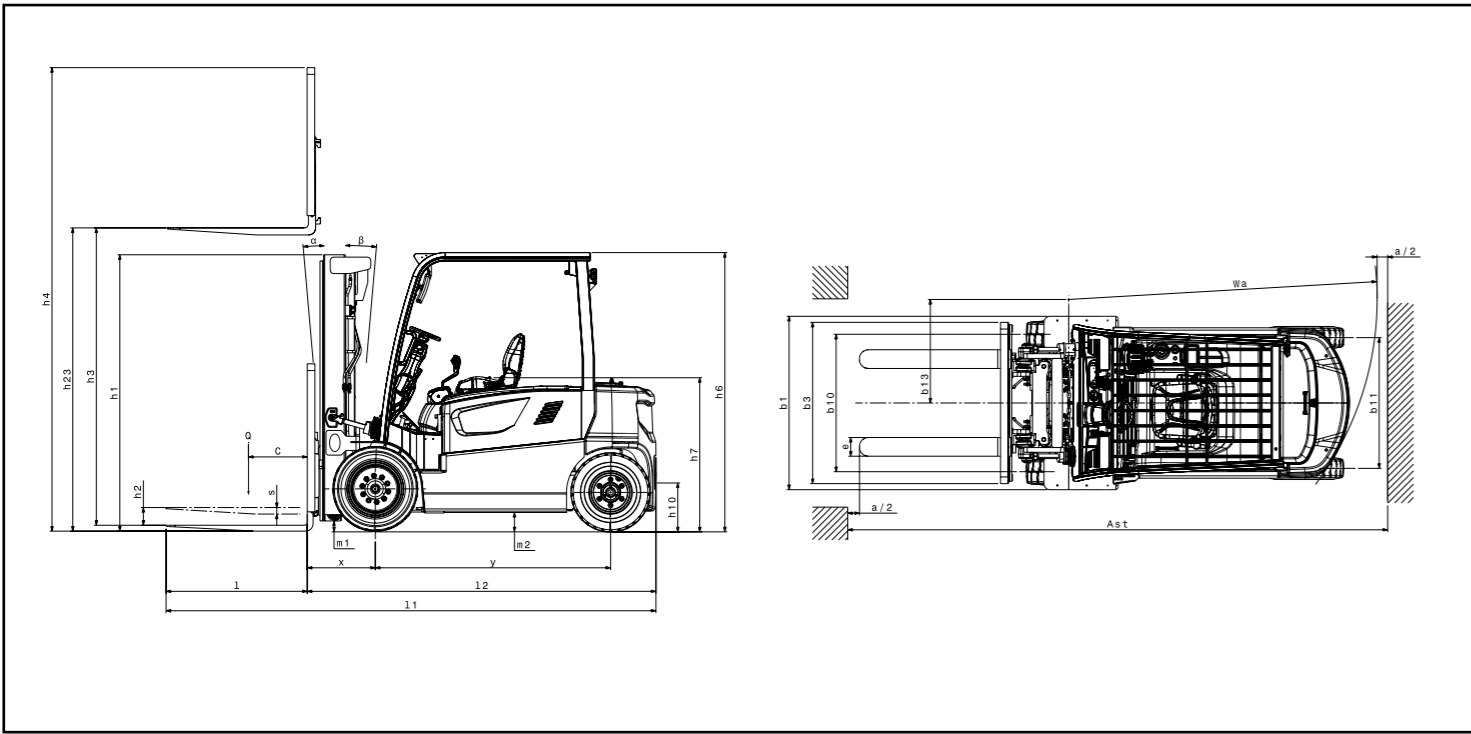

MAST SPECIFICATION and RATED CAPACITIES

B40X-7

Mast Type	Max. Fork Height mm	Mast Lowered Height mm	Extended Height w/ Load Backrest mm	Free Lift w/ Load Backrest mm	Rated Load Capacities		
					Tilt Angle		Load capacities LC 500mm kg
					Fwd deg	Bwd deg	
STD	3,000	2,190	4,265	160	6	9	4,000
	3,300	2,340	4,565	160	6	9	4,000
	3,650	2,515	4,915	160	6	9	4,000
	4,000	2,840	5,265	160	6	9	4,000
	4,250	2,965	5,515	160	6	9	4,000
FF	4,850	3,415	6,115	160	6	5	4,000
	3,000	2,170	4,240	970	6	9	4,000
FFT	4,000	2,050	5,265	850	6	9	4,000
	4,250	2,140	5,530	940	6	9	4,000
	4,700	2,290	5,980	1,090	6	9	4,000
	5,150	2,440	6,430	1,240	6	5	3,940
	5,600	2,590	6,880	1,390	6	5	3,810
	6,050	2,740	7,330	1,540	6	3	3,670

B45X-7

Mast Type	Max. Fork Height mm	Mast Lowered Height mm	Extended Height w/ Load Backrest mm	Free Lift w/ Load Backrest mm	Rated Load Capacities		
					Tilt Angle		Load capacities LC 500mm kg
					Fwd deg	Bwd deg	
STD	3,000	2,185	4,265	160	6	9	4,500
	3,300	2,335	4,565	160	6	9	4,500
	3,650	2,510	4,915	160	6	9	4,500
	4,000	2,835	5,265	160	6	9	4,500
	4,250	2,960	5,515	160	6	9	4,500
FF	4,850	3,410	6,115	160	6	5	4,500
	3,000	2,165	4,240	965	6	9	4,500
FFT	4,000	2,050	5,265	850	6	9	4,500
	4,250	2,135	5,530	935	6	9	4,500
	4,700	2,285	5,980	1,085	6	9	4,500
	5,150	2,435	6,430	1,235	6	5	4,500
	5,600	2,585	6,880	1,385	6	5	4,350
	6,050	2,735	7,330	1,535	6	3	4,225

B50XC-7

Mast Type	Max. Fork Height	Mast Lowered Height	Extended Height	Free Lift	Rated Load Capacities		
					w/ Load Backrest	w/ Load Backrest	Tilt Angle
			mm	mm			mm
STD	3,000	2,185	4,415	160	6	9	4,990
	3,300	2,335	4,715	160	6	9	4,990
	3,650	2,510	5,065	160	6	9	4,990
	4,000	2,835	5,415	160	6	9	4,990
	4,250	2,960	5,665	160	6	9	4,990
	4,850	3,410	6,265	160	6	5	4,990
FF	3,000	2,165	4,240	965	6	9	4,990
FFT	4,000	2,050	5,265	850	6	9	4,990
	4,250	2,135	5,530	935	6	9	4,990
	4,700	2,285	5,980	1,085	6	9	4,990
	5,150	2,435	6,430	1,235	6	5	4,810
	5,600	2,585	6,880	1,385	6	5	4,660
	6,050	2,735	7,330	1,535	6	3	4,480

B50X-7

Mast Type	Max. Fork Height	Mast Lowered Height	Extended Height	Free Lift	Rated Load Capacities		
					w/ Load Backrest	w/ Load Backrest	Tilt Angle
			mm	mm			mm
STD	3,000	2,185	4,415	160	6	9	5,000
	3,300	2,335	4,715	160	6	9	5,000
	3,650	2,510	5,065	160	6	9	5,000
	4,000	2,835	5,415	160	6	9	5,000
	4,250	2,960	5,665	160	6	9	5,000
	4,850	3,410	6,265	160	6	5	5,000
FF	3,000	2,165	4,390	815	6	9	5,000
FFT	4,000	2,050	5,415	700	6	9	5,000
	4,250	2,135	5,680	785	6	9	5,000
	4,700	2,285	6,130	935	6	9	5,000
	5,150	2,435	6,580	1,085	6	5	4,810
	5,600	2,585	7,030	1,235	6	5	4,660
	6,050	2,735	7,480	1,385	6	3	4,480

Note : Mast Specifications & Rated Capacities are based on standard chassis with pneumatic tire and without side shifter.

B50X-7-181107ENV1 (November 2018)



Doosan Industrial Vehicle Europe nv
 Europark-Noord 36A
 9100 Sint-Niklaas
 België
 Tel.: +32 3 760 09 87
 Fax: +32 3 760 09 89
 Website : www.doosan-iv.eu

